

**SOUTH SAN LUIS OBISPO COUNTY  
SANITATION DISTRICT**

Post Office Box 339, Oceano, California 93475-0339  
1600 Aloha, Oceano, California 93445-9735  
Telephone (805) 489-6666 FAX (805) 489-2765  
[www.sslocsd.us](http://www.sslocsd.us)

**AGENDA  
BOARD OF DIRECTORS' MEETING**

Wednesday, June 3, 2026, at 6:00 p.m.  
Arroyo Grande Council Chambers,  
215 E. Branch Street, Arroyo Grande, California 93420

**Board Members**

Caren Ray Russom, Chair  
Kassi Dee, Vice Chair  
Linda Austin, Director

**Agencies**

City of Arroyo Grande  
City of Grover Beach  
Oceano Community Services District

**Alternate Board Members**

Clint Weirick, Director  
Shirly Gibson, Director  
Jim Guthrie, Director

City of Grover Beach  
Oceano Community Services District  
City of Arroyo Grande

- 
- 1. CALL TO ORDER AND ROLL CALL**
  - 2. PLEDGE OF ALLEGIANCE**
  - 3. AGENDA REVIEW**
  - 4. PUBLIC COMMENTS ON ITEMS NOT APPEARING ON AGENDA**

This public comment period is an invitation to members of the community to present comments, thoughts or suggestions on matters not scheduled on this agenda. Comments should be limited to those matters which are within the jurisdiction of the District. The Brown Act restricts the Board from taking formal action on matters not published on the agenda. In response to your comments, the Chair or presiding Board Member may:

- Direct Staff to assist or coordinate with you.
- Direct Staff to place your issue or matter on a future Board meeting agenda.

Please adhere to the following procedures when addressing the Board:

- Comments should be limited to three (3) minutes or less.
- Your comments should be directed to the Board as a whole and not directed to individual Board members.
- Slanderous, profane or personal remarks against any Board Member, Staff or member of the audience shall not be permitted

Any writing or document pertaining to an open-session item on this agenda which is distributed to a majority of the Board after the posting of this agenda will be available for public inspection at the time the subject writing or document is distributed. The writing or document will be available for public review in the offices of the Oceano CSD, a member agency located at 1655 Front Street, Oceano, California. Consistent with the Americans with Disabilities Act (ADA) and California Government Code §54954.2, requests for disability-related modification or accommodation,

including auxiliary aids or services, may be made by a person with a disability who requires modification or accommodation in order to participate at the above referenced public meeting by contacting the District Administrator or Bookkeeper/Secretary at (805) 481-6903. So that the District may address your request in a timely manner, please contact the District two business days in advance of the meeting.

**5. CONSENT AGENDA:**

The following routine items listed below are scheduled for consideration as a group. Each item is recommended for approval unless noted. Any member of the public who wishes to comment on any Consent Agenda item may do so at this time. Any Board Member may request that any item be withdrawn from the Consent Agenda to permit discussion or to change the recommended course of action. The Board may approve the remainder of the Consent Agenda on one motion.

**5A. Approval of Warrants**

**5B. Approval of Meeting Minutes of April 1, 2026**

**5C. Request Approval to Purchase a Forklift Mr. Jackman Mk II**

**5D. Request Approval to Purchase Reclaim Water Filtration System**

**6. ACTION ITEMS:**

**6A. PUBLIC HEARING TO CONSIDER ENTERING INTO ENERGY SERVICE CONTRACT PURSUANT TO GC 4217**

Recommendation: Continue to July 1, 2026.

**6B. 2026/27 FISCAL YEAR BUDGET; SET PUBLIC HEARING FOR JULY 1, 2026**

Recommendation:

1. That the Board Provide Input Regarding the Proposed 2026-27 Fiscal Year (FY) Budget and,
2. Set a Noticed Public Hearing for July 1, 2026.

**6C. REQUEST APPROVAL TO PURCHASE FLOW AND LEVEL MONITORING EQUIPMENT**

Recommendation: That the Board of Directors approve and authorize the District Administrator to purchase new flow and level monitoring equipment in the amount of \$31,746.

**6D. DISTRICT ADMINISTRATOR AND PLANT OPERATIONS REPORT**

Recommendation: Receive and File

**7. BOARD MEMBER COMMUNICATIONS:**

**8. ADJOURNMENT**

The next regularly scheduled Board Meeting is  
July 1, 2026, 6:00 pm at the  
Oceano Community Services District,  
1655 Front St, Oceano CA 93445

WARRANT REGISTER  
6/3/2026  
FISCAL YEAR 2025/26

VENDOR	BUDGET LINE ITEM	DETAIL	WARRANT NO.	ACCT	ACCT BRKDN	TOTAL
AGILE OCCUPATIONAL MEDICINE	SAFETY	EM076279	040826-9212	8056	146.00	146.00
AGP VIDEO	PROFESSIONAL SERVICE	MARCH 2026	9213	7080	650.00	650.00
AIRFLOW FILTER	EQUIPMENT MAINTENANCE	83692	9214	8030	270.40	270.40
ALLIED ADMINSITRATORS	DENTAL	MAY 2026	9215	6025	1,017.40	1,017.40
AUTOSYS, LLC	SCADA	0461	9216	7051	2,822.17	2,822.17
BRENNTAG	PLANT CHEMICALS	BPI592229	9217	8050	9,668.33	9,668.33
BRISCO MILL & LUMBAR	EQUIPMENT MAINTENANCE	172713	9218	8030	241.58	241.58
CALPORTLAND COMPANY	STRUCTURE MAINTENANCE	DRAIN PROJECT	9219	8060	583.76	583.76
CAREN RAY RUSSOM	BOARD SERVICE	APRIL 1, 2026	9220	7075	100.00	100.00
CHARTER COMMUNICATIONS	COMPUTER SUPPORT	03/29/26-04/28/26	9221	7013	334.51	334.51
COASTAL ROLLOFF	RUBBISH	MARCH 2026	9222	7093	705.47	705.47
COLD CANYON LANDFILL	RUBBISH	46442D100	9223	7093	468.25	468.25
COLUMBIA BANK	CREDIT CARD	MARCH 2026	9224		4,122.30	4,122.30
CREATIVE FENCE	STRUCTURE MAINTENANCE	S26-17	9225	8060	2,890.00	2,890.00
CULLIGAN WATER	RENTAL EQUIPMENT	133325	9226	7032	60.00	60.00
ENGEL & GRAY	BIOSOLIDS HANDLING	63X00010	9227		10,242.57	10,242.57
EVERYWHERE RIGHT NOW	COMPUTER SUPPORT	4724	9228	7082	100.00	100.00
FEDEX	CHEMICAL ANALYSIS	MULTIPLE	9229	7078	113.45	113.45
GRAINGER	EQUIPMENT MAINTENANCE	MULTIPLE	9230	8030	813.39	813.39
HACH COMPANY	LAB SUPPLIES	1492721	9231	8040	496.23	496.23
II SUPPLY	SAFETY	MULTIPLE	9232	8056	178.46	178.46
JB DEWAR	FUEL	459159; 461266	9233	8020	643.68	643.68
JNE CONCRETE	STRUCTURE MAINTENANCE	DRAIN PROJECT	9234	8060	10,850.00	10,850.00
KASSANDRA DEE	BOARD SERVICE	APRIL 1, 2026	9235	7075	100.00	100.00
LINDE GAS	EQUIPMENT RENTAL	55640029	9236	7032	52.43	52.43
MCMASTER CARR	EQUIPMENT MAINTENANCE	MULTIPLE	9237	8030	317.06	317.06
MINERS	EQUIPMENT MAINTENANCE	MARCH 2026	9238	8030	478.94	478.94
NBS	AGENCY BILLING	APRIL TO JUNE	9239	7074	2,413.00	2,413.00
NOBLE POWER EQUIPMENT	EQUIPMENT MAINTENANCE	680071	9240	8030	47.85	47.85
OCSO	WATER	01/18/26-03/18/26	9241	7094	1,329.52	1,329.52
OILFIELD ENVIRONMENTAL	CHEMICAL ANALYSIS	MULTIPLE	9242	7078	4,695.00	4,695.00
PRIMO BRANDS	ADMIN BUILDING	02/25/26-03/24/26	9243	8045	615.79	615.79
QUINN CAT	EQUIPMENT RENTAL	34711501	9244		1,841.86	1,841.86
RAIN FOR RENT	RENTAL EQUIPMENT	2251789	9245	7032	754.00	754.00
SAN LUIS POWERHOUSE	EQUIPMENT MAINTENANCE	54724	9246	8030	3,706.74	3,706.74
SANTA MARIA FAMCON PIPE	EQUIPMENT MAINTENANCE	S100175942.001	9247	8030	2,809.95	2,809.95
SHIRLEY GIBSON	BOARD SERVICE	APRIL 1, 2026	9248	7075	100.00	100.00
SO CAL GAS	GAS	03/03/26-04/01/26	9249	7092	5,198.19	5,198.19
SO CO SANITARY	RUBBISH	APRIL 2026	9250	7093	406.18	406.18
SSLOCSO	EMPLOYEE BENEFITS	MARCH 2026	9251		133,173.84	133,173.84
STATEWIDE SAFETY	SAFETY	3026367	9252	8056	336.00	336.00
T-MOBILE	CELL PHONE	02/16/26-03/15/26	9254	7014	61.84	61.84
VESTIS	EMPLOYEE UNIFORMS	03/23/26; 03/30/26; 04/06/26	9255	7025	1,803.21	1,803.21
VWR INTERNATIONAL	LAB SUPPLIES	2026-422; 423	9256	8040	651.21	651.21
ACE CERTIFIED TREE CARE	STRUCTURE MAINTENANCE	20252528	042226-9257	8060	3,000.00	3,000.00
AMERICAN BUSINESS MACHINES	OFFICE SUPPLIES	862177	9258	8045	110.35	110.35
BRENNTAG	PLANT CHEMICALS	BPI594712	9259	8050	16,350.10	16,350.10
COASTAL JANITORIAL	STRUCTURE MAINTENANCE	APRIL 2026	9260	8060	813.75	813.75
COUNTY OF SLO EMERGENCY	PERMITS	2026019	9261		1,250.00	1,250.00
FEDEX	OFFICE SUPPLIES	9-249-80915	9262	7078	69.78	69.78
GSOLUTIONZ	COMMUNICATIONS	7684	9263	7013	370.16	370.16
II SUPPLY	EQUIPMENT MAINTENANCE	111351; 111352	9264	8030	90.50	90.50
JR FILANC	REDUNDANCY	CONDITIONAL WAIVER RELEASE	9265	20-7080	313,358.31	313,358.31
KENNEDY JENKS	REDUNDANCY	FINAL INVOICE	9266	20-7080	8,118.75	8,118.75
MICHAEL K NUNLEY	ENGINEERING	3052	9267	7077	170.25	3,047.50
	CONDITION ASSESMENT	3051		26-8065	937.25	
	STRUCTURE MAINTENANCE	3087		26-8065	1,940.00	
OILFIELD ENVIRO COMPLIANCE	CHEMICAL ANALYSIS	MULTIPLE	9268	7078	3,900.00	3,900.00
PG&E	ELECTRICITY	03/11/26-04/08/26	9269	7091	30,630.56	30,630.56
POLYDYNE	PLANT CHEMICALS	2019586	9270	8050	8,859.08	8,859.08
RINCON	COASTAL HAZARDS MONITORING	7437	9271	7020	1,669.75	1,669.75
SAFETY KLEEN	CHEMICAL ANALYSIS	99446930	9272	7078	315.02	315.02
SWRCB ELAP FEES	PERMITS	EA-LA-0326-1413	9273		6,500.00	6,500.00
THE SHERWIN WILLIAMS CO	EQUIPMENT MAINTENANCE	0891-6	9274	8030	240.61	240.61
VESTIS	UNIFORMS	04/13/26	9275	7025	602.04	602.04
<b>SUB TOTAL</b>					<b>607,706.82</b>	<b>607,706.82</b>

CONTIUED ON NEXT PAGE

WARRANT REGISTER  
6/3/2026 CONTINUED  
FISCAL YEAR 2025/26

VENDOR	BUDGET LINE ITEM	DETAIL	WARRANT NO.	ACCT	ACCT BRKDN	TOTAL
ACE CERTIFIED TREE CARE	EQUIPMENT MAINTENANCE	ACCESS RD. 2026	050726-9276	8030	1,500.00	1,500.00
B&B STEEL	EQUIPMENT MAINTENANCE	775389	9277	8030	722.65	722.65
BRENNTAG	PLANT CHEMICALS	MULTIPLE	9278	8050	24,766.35	24,766.35
CHARTER COMMUNICATIONS	COMPUTER SUPPORT	04/29/26-05/28/26	9279	7013	334.38	334.38
CITY OF ARROYO GRANDE	AGENCY BILLING	JULY 2025 TO MARCH 2026	9280		38,085.50	38,085.50
COLUMBIA BANK	CREDIT CARD	APRIL 2026	9281		6,933.84	6,933.84
FEDEX	CHEMICAL ANALYSIS	MULTIPLE	9282	7078	243.75	243.75
FGL ENVIRONMENTAL	CHEMICAL ANALYSIS	681222A	9283	7078	458.00	458.00
GRAINGER	EQUIPMENT MAINTENANCE	MULTIPLE	9284	8030	2,464.14	2,464.14
IDEXX DISTRIBUTION INC	LAB SUPPLIES	3198973934	9285	8040	56.35	56.35
II SUPPLY	SAFETY	MULTIPLE	9286	8056	229.93	229.93
JB DEWAR	FUEL	465333	9287	8020	150.34	150.34
LINDE GAS	EQUIPMENT RENTAL	56233855	9288	7032	55.01	55.01
MCMASTER CARR	EQUIPMENT MAINTENANCE	MULTIPLE	9289	8030	323.10	323.10
MINERS	EQUIPMENT MAINTENANCE	APRIL 2026	9290	8030	1,668.55	1,668.55
OILFIELD ENVIRONMENTAL	CHEMICAL ANALYSIS	MULTIPLE	9291	7078	1,870.00	1,870.00
PRIMO BRANDS	ADMIN BUILDING	03/25/26-04/24/26	9292	8045	388.68	388.68
RAIN FOR RENT	RENTAL EQUIPMENT	2261740	9293	7032	754.00	754.00
SANTA MARIA FAMCON PIPE	EQUIPMENT MAINTENANCE	S100179971.001	9294	8030	456.75	456.75
SECURTIAS TECHNOLOGY	ALARMS	MAY 2026	9295		88.31	88.31
SSLOCSD	EMPLOYEE BENEFITS		9296		144,060.87	144,060.87
T-MOBILE	CELL PHONE	03/16/26-04/15/26	9297	7014	61.76	61.76
USA BLUEBOOK	EQUIPMENT MAINTENANCE	INV01033939	9298	8030	562.96	562.96
VESTIS	EMPLOYEE UNIFORMS	04/20/26; 04/27/26	9299	7025	1,209.87	1,209.87
VWR INTERNATIONAL	LAB SUPPLIES	2026-427	9300	8040	110.73	110.73
ACE CERTIFIED TREE CARE	STRUCTURE MAINTENANCE	MULTIPLE	051526-9301	8060	3,800.00	3,800.00
AGILE OCCUPATIONAL MEDICINE	SAFETY	EN079531	9302	8056	29.00	29.00
AGP VIDEO	PROFESSIONAL SERVICE	APRIL 2026	9303	7080	650.00	650.00
ALLIED ADMINISTRATORS	EMPLOYEE DENTAL	JUNE 2026	9304	6025	1,017.40	1,017.40
AT&T MOBILITY	CELL PHONE	04/03/26-05/02/26	9305	7013	81.48	81.48
AUTOSYS, LLC	SCADA	INV-0476	9306	7051	2,118.33	2,118.33
BRENNTAG	PLANT CHEMICALS	BPI601664	9307	8050	9,944.26	9,944.26
BRISCO MILL AND LUMBAR	EQUIPMENT MAINTENANCE	MULTIPLE	9308	8030	287.93	287.93
COASTAL JANITORIAL	STRUCTURE MAINTENANCE	MAY 2026	9309	8060	775.00	775.00
COASTAL ROLLOFF	RUBBISH	APRIL 2026	9310	7093	1,631.76	1,631.76
COLD CANYON LANDFILL	RUBBISH	46613D100	9311	7093	378.50	378.50
CULLIGAN WATER	ADMIN BUILDING	133949	9312	7032	301.40	301.40
EMPLOYEE DEVPMT DEPT	UNEMPLOYMENT	THROUGH MARCH 2026	9313	6095	450.03	450.03
ENGEL & GRAY	BIOSOLIDS	APRIL 2026	9314		11,380.03	11,380.03
EVERYWHERE RIGHT NOW		MAY 2026	9315	7082	100.00	100.00
FEDEX	OFFICE SUPPLIES	9-279-92742	9316	7078	526.16	526.16
FERGUSON ELECTRICAL	ELECTRICIAN	1399	9317	7062	1,890.00	1,890.00
FGL ENVIRONMENTAL	CHEMICAL ANALYSIS	MULTIPLE	9318	7078	478.00	478.00
FOSTER & FOSTER	AUDIT	15548T	9319		1,710.00	1,710.00
GRAINGER	EQUIPMENT MAINTENANCE	MULTIPLE	9320	8030	409.90	409.90
GSOLUTIONZ	COMMUNICATIONS	MAY AND JUNE 2026	9321	7013	211.26	211.26
JB DEWAR	FUEL	467394; 469300	9322	8020	615.14	615.14
POLYDYNE	PLANT CHEMICALS	2026318	9323	8050	8,859.08	8,859.08
RINCON	COASTAL HAZARDS MONITORING	74047	9324	7020	11,600.00	11,600.00
RS FIRE PROTECTION	SAFETY	SSCSD5526	9325	8056	1,045.92	1,045.92
SO CAL GAS	UTILITY GAS	04/01/26-04/30/26	9326	7092	4,787.86	4,787.86
SO CO SANITARY SERVICE	RUBBISH	MAY 2026	9327	7093	407.19	407.19
V LOPEZ JR & SONS	TRUNK SEWER MAINTENANCE	15428	9328	8015	2,500.00	2,500.00
VESTIS	EMPLOYEE UNIFORMS	05/04/26; 05/11/26	9329	7025	1,207.29	1,207.29
VWR INTERNATIONAL	LAB SUPPLIES	2026-427	9330	8040	236.47	236.47
D&H WATER SYSTEMS	STRUCTURE MAINTENANCE	I2026-0584; 0643	052026-9331	26-8065	20,744.11	20,744.11
FERGUSON ELECTRICAL SYSTEMS	ELECTRICIAN	1407	9332	19-7062	2,158.00	2,158.00
PG&E	ELECTRICITY	04/09/26-05/07/26	9333	7091	30,824.76	30,824.76
SM TIRES	AUTOMOTIVE	535410	9334	8032	1,020.91	1,020.91
CAREN RAY RUSSOM	BOARD SERVICE	MAY 6, 2026	9335	7075	100.00	100.00
KASSANDRA DEE	BOARD SERVICE	MAY 6, 2026	9336	7075	100.00	100.00
SHIRLEY GIBSON	BOARD SERVICE	MAY 6, 2026	9337	7075	100.00	100.00
USDA RURAL DEVELOPMENT			9338		30,942.25	30,942.25
<b>SUB TOTAL</b>					<b>382,975.24</b>	<b>382,975.24</b>
<b>GRAND TOTAL</b>					<b>990,682.06</b>	<b>990,682.06</b>

We hereby certify that the demands numbered serially from 040826-9212 to 052026-9338 together with the supporting evidence have been examined, and that they comply with the requirements of the SOUTH SAN LUIS OBISPO COUNTY SANITATION DISTRICT. The demands are hereby approved by motion of the SOUTH SAN LUIS OBISPO COUNTY SANITATION DISTRICT, together with warrants authorizing and ordering the issuance of checks numbered identically with the particular demands and warrants.

BOARD OF DIRECTORS:

DATE:

Chairman

Secretary

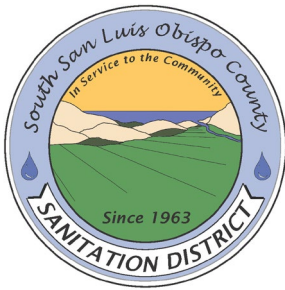

# SOUTH SAN LUIS OBISPO COUNTY SANITATION DISTRICT

Post Office Box 339, Oceano, California 93475-0339  
1600 Aloha, Oceano, California 93445-9735  
Telephone (805) 489-6666 FAX (805) 489-2765  
www.sslocsd.org

## SUMMARY ACTION MINUTES Meeting of Wednesday, April 1, 2026

---

### 1. CALL TO ORDER AND ROLL CALL

Chair Caren Ray Russom called the meeting to order and recognized a quorum.

Present: Caren Ray Russom, Director, City of Arroyo Grande  
Kassi Dee, Chair, City of Grover Beach  
Shirley Gibson, Vice Chair, Oceano Community Services District

District Staff: Jeremy Ghent, District Administrator  
Mychal Jones, Plant Superintendent  
Wendy Stockton, District Legal Counsel  
Amy Simpson, District Business & Accounting Analyst

### 2. PLEDGE OF ALLEGIANCE

### 3. AGENDA REVIEW

**Action:** Approved as presented.

### 4. PUBLIC COMMENTS ON ITEMS NOT APPEARING ON AGENDA

### 5. CONSENT AGENDA:

5A. Approval of Warrants

5B. Approval of Meeting Minutes of March 4, 2026

There was no public comment.

**Motion:** Director Kassi Dee motioned to approve the Consent Agenda as presented.

**Second:** Director Gibson

**Action:** Approved unanimously by voice vote.

**6. ACTION ITEMS:**

**6A. AUTHORIZATION TO RECLASSIFY THE BOOKKEEPER/SECRETARY POSITION TO BUSINESS & ACCOUNTING ANALYST AND ADOPT SALARY RANGE (CONTINUED)**

District Administrator Ghent presented this item.

There was no public comment.

**Motion:** Director Ray Rusom motioned to approve the reclassification of the Bookkeeper/Secretary position to Business & Accounting Analyst and adopt the associated salary range. This action is retroactive to the first payroll that followed the March 4<sup>th</sup> Board Meeting.

**Second:** Director Kassi Dee

**Action:** Approved unanimously by voice vote.

**6B. DISTRICT ADMINISTRATOR AND PLANT OPERATIONS REPORT**

Superintendent Mychal Jones presented the Plant Operations report. There were no violations of the District's National Pollutant Discharge Elimination System (NPDES) Permit during the March 2026, reporting period. All regulatory required analyses were within Permit limitations.

District Administrator Jeremy Ghent presented the Administrator Report.

There was no public comment.

**Action:** The Board received and filed this report.

**7. BOARD MEMBER COMMUNICATIONS**

None.

**8. ADJOURNMENT:**

6:20 p.m.

***THESE MINUTES ARE DRAFT AND NOT OFFICIAL UNTIL APPROVED BY THE BOARD OF DIRECTORS AT A SUBSEQUENT MEETING.***



# SOUTH SAN LUIS OBISPO COUNTY SANITATION DISTRICT

Post Office Box 339, Oceano, California 93475-0339  
1600 Aloha Oceano, California 93445-9735  
Telephone (805) 489-6666 FAX (805) 489-2765  
www.sslocsd.org

---

## Staff Report

**To:** Board of Directors  
**From:** Jeremy Ghent, District Administrator  
**Via:** Mychal Jones, Plant Superintendent  
**Date:** June 3, 2026

**Subject: REQUEST APPROVAL TO PURCHASE A FORKLIFT**

### **RECOMMENDATION:**

1. That the Board of Directors approve and authorize the District Administrator to purchase a new forklift in the amount of \$49,969; and
2. Authorize staff to surplus and dispose of the existing forklift.

### **BACKGROUND AND DISCUSSION:**

The District budgeted for the purchase and replacement of the existing forklift in the current fiscal year. The existing forklift has reached the end of its service life and is due for replacement. Staff is requesting approval to purchase a replacement forklift and authorization to dispose of the existing unit.

District staff solicited and received quotes from three vendors. The selected quote from Papé Material Handling is \$49,969 for a Hyster H60A lift truck with a 6,000-pound nominal capacity.

Staff recommends proceeding with the Hyster forklift based on performance, reliability, and staff familiarity with the existing Hyster equipment being replaced.

In accordance with District Resolution No. 2025-463, the new forklift will be named "Mr. Jackman" in recognition and appreciation of Senior Operator William "Rick" Jackman's service to the District.

### **FISCAL CONSIDERATION:**

Adequate funding was included in the adopted Fiscal Year 2025/26 Budget under Fund 26, Account No. 26-8065.

### **Attachment:**

Quotes



PAPE MATERIAL HANDLING  
 1322 WHITE COURT  
 SANTA MARIA, California 93458  
 Phone: 805-660-5286



**MODEL: H60A**

All trucks shown with optional equipment. Please refer to quotation specifications.

**CUSTOMER DETAILS**

CUSTOMER	South San Luis Obispo County Sanitation - Oceano		
ADDRESS	PO Box 339 Oceano, California 93475		
SHIP-TO ADDRESS	1600 Aloha Street Oceano, California 93445		
CONTACT NAME	Jerry Benavidez	TITLE	Warehouse Manager
PHONE	805-925-5411		
PROPOSED BY	James Bevill	TITLE	PSR/TM
PHONE	805-503-7379	EMAIL	jbevill@papemh.com
DATE	2025-08-25	Quote Expiration	2025-09-24



PAPE MATERIAL HANDLING  
 1322 WHITE COURT  
 SANTA MARIA, California 93458  
 Phone: 805-660-5286



## Quoted Model: H60A Available Features

Hyster® H60A Lift Truck - 6,000 lb. Nominal Capacity, Class V

## Proposal Summary

Included Items	Description	Quantity
Model	Hyster® H60A Lift Truck - 6,000 lb. Nominal Capacity, Class V	1
Construction	Keyswitch Start Standard (-4° F to 104° F) Noise Reduction Package	
Powertrain	Engine -- Yanmar 2.1L Turbocharged Diesel with DOC (59hp) Brakes - Self Energizing Drum Single Pedal Inch/Brake Arrangement Duramatch™ Transmission	
Powertrain Options	Heavy Duty High Air Intake Low Exhaust UL Label - Classification Type D Fuel Cap - Non-lockable	
Powertrain Accessories	System Monitoring	
Mast	3 Stage Full Free Lift Mast - Class III - 181" (4620mm) Maximum Lift Height - 86" (2195mm) Overall Lowered Height [Heavy duty] Mast Tilt - 6° Forward / 6° Back	
Carriages & Attachments	42" (1067mm) Wide - Class III - Hook Type Integral Sideshift Carriage 48" (1220mm) High Load Backrest Extension	
Forks	48" Long x 2.0" Thick x 4.9" Wide (1220mm x 50mm x 125mm) - Class III Hook Type - Standard Taper Forks	
Hydraulics	3 Function (1 Auxiliary) Hydraulic Control Valve Mechanical Lever Hydraulic Controls - Cowl Mounted Engine Driven Cooling System Standard Displacement Hydraulic Pump	
Hoses	1 Auxiliary Function Hose Group - 2 Hoses Internally Mounted	
Wheels & Tires	Standard Tread Width Drive Tires - 28 x 9-15 14 - Pneumatic - Premium 6.50 x 10-12 Pneumatic Steer Tires	
Operator Compartment	85" Rectangular Tube - High Grid Style Overhead Guard Mirrors - Dual Side View - Mounted on the Left and Right Side of Overhead Guard Premium Display: 7" Color Touchscreen Fire Extinguisher - 2.5 lb. Dry Chemical Console Tray Dynamic Stability System	



PAPE MATERIAL HANDLING  
 1322 WHITE COURT  
 SANTA MARIA, California 93458  
 Phone: 805-660-5286



Directional Control	Rear Drive Handle with Horn Button Lever Shift Direction Control - Mounted on Left Hand Side of Steering Column Steer Column with Infinitely Adjustable Tilt On Demand Hydrostatic Power Assist Steering
Seat	Steering Wheel with Spinner Knob Full Suspension Vinyl Seat [Premium] Seat Belt - High-Visibility (Red) - No-Cinch with ELR (Emergency Locking Retractor) and Start Interlock
Chassis Options	Hood Front Mud Guards
Lights & Alarms	LED Brake/Tail/Backup Manual Work Light Control LED Work Lights - 2 Front, 1 Rear [Premium] Audible Alarm - Reverse Direction Activated - Self-Adjusting 82-102 dB(A) Amber Strobe Light - Ignition Activated
Warranty	12 Months / 2,000 Hours Manufacturer's Warranty, 36 Months / 6,000 Hours Powertrain Warranty; please see full Warranty Statement for additional details.
Literature & Nameplate	English Literature Pack and Labels
Fees & Surcharges	Freight Fees & Surcharges Destination Charge

## Additional Items or Accessories Included

Description	Quantity
-------------	----------



PAPE MATERIAL HANDLING  
 1322 WHITE COURT  
 SANTA MARIA, California 93458  
 Phone: 805-660-5286



## Total Investment

<b>Price H60A</b>	\$49,969.00	<b>Qty:</b> 1
<b>Quoted Quantity</b>	1	<b>TOTAL:</b> \$49,969.00

F.O.B. Factory (factory freight not included). Price is exclusive of any taxes. Due to volatility of supply chain, transportation, lead times etc., we reserve the right to revise our pricing in direct correlation to price surcharges/increases received from the OEM. Lease payment quotes are subject to possible interest rate indexing at time of delivery. This sales order/proposal is subject to Pape' Material Handling's Terms and Conditions of Sale effective on the date hereof, which are incorporated in full by this reference. The Terms and Conditions of Sale are available at [www.pape.com/terms](http://www.pape.com/terms), and will also be sent by mail or email to Buyer upon request.

<b>Proposal By:</b>	James Bevill	<b>Accepted By:</b>	_____
<b>Signature:</b>	_____	<b>Signature:</b>	_____
<b>Date Signed:</b>	_____	<b>Date Accepted:</b>	_____
		<b>PO Number:</b>	_____

# QUOTATION

Address: 4701 Oak Port Street  
Oakland, CA 94601

PREPARED FOR	
Customer:	South San Luis Obispo County Sanitation
Address:	1600 Aloha Place Oceano, CA 93445

REFERENCE	
Effective From:	Friday, September 12, 2025
Effective To:	Sunday, October 12, 2025
Quote #:	841120
Account Manager:	
Direct Phone:	
E-mail:	

## Towlift Inc Key Advantages

Thank you for the opportunity to present the following proposal for your material handling needs. Since 1965 it has been our mission to be the leader in providing material handling solutions.



## DP25N5 - 5,000 lb. Capacity Tier 4 Final Compliant Diesel Pneumatic Tire Lift Truck

### HIGHLIGHTS

#### Uncompromising Performance



### KEY FEATURES & BENEFITS

<b>EXCEPTIONAL PERFORMANCE</b>	After years of expertise and leadership in material handling solutions, Cat® lift trucks engineered a game changing powertrain for exceptional performance in the toughest material handling conditions. The EG engine family is the industry's most powerful and respected industrial engine family in its class. The engines delivers outstanding performance while maintaining the highest standards of durability and reliability. With a proven track record for quality and dependability, the rugged PowerShift transmission delivers a remarkable performance optimizing engine power and response.
<b>OPERATOR COMFORT</b>	A forklift's productivity is not only measured by a strong powertrain, but also by its operator comfort and efficiency. This is why Cat® lift trucks designed an ergonomic operator compartment optimizing comfort, visibility and productivity for long and demanding shifts.
<b>PRESENCE DETECTION SYSTEM</b>	The Patented PDS system, standard on all Cat® lift trucks helps ensure that the operator is following the correct operating procedures. Once the operator leaves the seat and does not engage the park brake, the PDS will disengage the transmission and all hydraulic functions to the mast while activating an audible alarm and a flashing visual warning.
<b>ENGINE PROTECTION SYSTEM</b>	The EPS monitors the Engine Coolant Temperature, Transmission Oil Temperature and Engine Oil Pressure. The system issues a warning and cuts back on engine rpm when parameters go



## DP25N5 - 5,000 lb. Capacity Tier 4 Final Compliant Diesel Pneumatic Tire Lift Truck

out of range. It also monitors the brake fluid level and warns when the level is too low. The EPS also issues periodic maintenance alerts by displaying them on the screen.

### PREMIUM LED/LCD DISPLAY

The standard premium LED/LCD display is connected to the monitoring system alerting the operator if one of the systems is not in check. It includes a Speedometer, Hour Meter, Clock, Travel Direction, Low Fuel Indicator or Fuel Gage, Coolant Temperature, Battery Charging Status, Operator Passcode capability and other systems-related indicators & warnings.

### CONFIGURATION

CHASSIS	1	5,000 lb. Capacity Tier 4 Final Compliant Diesel Pneumatic Tire Lift Truck
MAST	1	188.0" MFH / 84.5" OAL / 36.0" FFH Triplex. .
FORKS	1	1.6" X 3.9" X 48" Hook Type - Pallet
RATINGS & STANDARDS	1	UL Approved
RATINGS & STANDARDS	1	EPA Compliant
POWERTRAIN	1	Mitsubishi 4EG 3.3L 4 Cylinder Diesel Engine
POWERTRAIN	1	Single Speed Powershift Transmission
CARRIAGE	1	39.5" Wide ITA Class II Hook Type Carriage
SIDESHIFTER	1	39.5" Wide ITA Class II Hang-On Sideshifter and Fork Positioner
DRIVE & STEER TIRES	1	Solid Pneumatic Single Drive And Steer Tires
LOAD BACKREST	1	48" High Load Backrest
HYDRAULIC ACTIVATION	1	3-Section Valve
HYDRAULIC HOSE OPTIONS	1	Single Function Internal Hosing - Triplex Mast
TILT CYLINDERS	1	Standard Tilt Cylinders
OVERHEAD GUARD	1	Standard Overhead Guard
PRODUCTIVITY OPTIONS	1	Premium LCD/LED Display
PRODUCTIVITY OPTIONS	1	Ground Speed Control
PRODUCTIVITY OPTIONS	1	Engine Protection System
PRODUCTIVITY OPTIONS	1	Separate Brake & Inching Pedals
PRODUCTIVITY OPTIONS	1	Fuel Saver Mode
PRODUCTIVITY OPTIONS	1	Rear Grab Handle With Horn Button
PRODUCTIVITY OPTIONS	1	Steering Wheel Knob
SPECIAL APPLICATIONS OPTIONS	1	Aluminum Core Corrugated Fin Radiator
SPECIAL APPLICATIONS OPTIONS	1	Presence Detection System
SPECIAL APPLICATIONS OPTIONS	1	Heavy Duty Counterweight Grill
WARNING / LIGHT OPTIONS	1	Two Forward LED Working Lights On OHG
WARNING / LIGHT OPTIONS	1	Electronic Back-up Alarm
WARNING / LIGHT OPTIONS	1	Rear LED Stop/Tail/Back-up Combination Lights
WARNING / LIGHT OPTIONS	1	Amber Strobe Light - Mounted Above OHG
SEAT	1	Full Suspension Vinyl Seat
ACCESSORIES	1	Orange Seat Belt
ACCESSORIES	1	Rubber Floor Mat
ACCESSORIES	1	Operator Convenience Tray With Clipboard Holder
ACCESSORIES	1	Dual Panoramic Rear View Mirror Kit
LANGUAGE MARKINGS	1	English Language Markings

### DP25N5 WARRANTY

DP25N5 Standard Warranty - 12 Months, 2000 Hours Full Coverage; 24 Months, 4000 Hours Powertrain

### DP25N5 INVESTMENT SUMMARY

QTY	DESCRIPTION	UNIT PRICE	EXTENDED PRICE	ACCEPTED
1	CAT 5,000 lb. Capacity Tier 4 Final Compliant Diesel Pneumatic Tire Lift Truck	\$60,865.50	\$60,865.50	
<b>SPECIFIED INVESTMENT TOTAL:</b>			<b>\$60,865.50</b>	

### QUOTATION / PROPOSAL TERMS AND CONDITIONS

Unless otherwise indicated in the proposal, the following terms and conditions are applicable. Terms and conditions of Sale and Service, available on our website, are an integral part of these proposal terms and conditions and all orders are subject to the same. Seller's terms and conditions are subject to change.

**PROPOSAL VALIDITY PERIOD:** Unless otherwise stated, written proposals shall expire automatically seven (7) days after the date appearing on the proposal unless the Seller receives and accepts Customer's order within that period.

**STANDARD TERMS:** Unless otherwise agreed to by the parties in writing, payment terms are Net 10 days from delivery, subject to credit approval. Lease rates are subject to credit approval/documentation. Special order forklifts or equipment require a 25% minimum deposit. Lease payment and/or sale price does not include any applicable tax, surcharges or freight (unless specified). Purchase and lease pricing are subject to change after an accepted order due to 1) tariff surcharge based on the existing federal requirements in force at the time of invoice and 2) inflationary raw material, component, and supply chain issues.

If the purchase price of the equipment/material being sold has not been paid in full prior to the delivery of the equipment/material being sold, the Purchaser agrees to execute at the Seller's request all documents necessary to create and perfect a security interest in said equipment/material. Should Customer fail to make payments when due, Seller may enter Customer's premise and repossess the product. In addition, the Customer shall pay any and all expenses and reasonable attorneys' fees incurred in repossessing and storing any product. All overdue amounts are subject to a finance charge of 1.5% per month as permissible in the jurisdiction.

**SHIPMENT:** Unless otherwise stated, all prices for equipment are F.O.B. factory or point of shipment. Partial shipments are fully payable according to the terms of this agreement.

**DELIVERY:** Estimated lead times and delivery dates are based upon Seller's current judgment and are subject to change. Estimated delivery is based on receipt of completed order, approved financial packages, and all terms and conditions being accepted by Customer. Seller will not be responsible for deliveries later than promised due to causes beyond its reasonable control.

**CANCELLATION OR CHANGES:** Accepted orders cannot be canceled, reduced, or revised, or delivery deferred for greater than 30 days, without Seller's written consent with terms that will indemnify Seller of all losses, costs and expenses. With cancellation, a minimum 25% cancellation fee may be charged to be paid immediately to Seller, along with other losses incurred.

**MISCELLANEOUS:** Customer represents that it shall possess and will maintain all applicable and required permits, licenses, approvals, registrations, consents and certificates. Other financing options and terms may be available (including financing sales tax). Please consult with your product specialist representative for additional financing options.

**ENTIRE AGREEMENT:** This writing and the Seller's Terms and Conditions of Sale and Service constitute the entire agreement between the parties. Seller shall not be bound by any terms of Customer's purchase order which provide conditions additional to or different from the terms hereof. Any modification must be made in writing and approved by both parties. If the terms of this proposal conflict with the Seller's Terms and Conditions of Sale and Service, these Terms shall control.

<b>ACCEPTANCE AS CONTRACT OF SALE</b>	
<b>Authorized agent understands and agrees to the Terms and Conditions as included with this Quote</b>	
<input type="text"/>	<b>Towlift Inc</b>
_____ Authorized Agent Signature	_____ Authorized Agent Signature
_____ Date Signed	_____ Date Signed
_____ Printed name	_____ Printed name
_____ Title/Position	_____ Title/Position
_____ Customer Purchase Order Number	
<i>Please consult with your accountant, tax professional, or equivalent to confirm characterization of equipment and tax implications. Other financing options and terms may be available (including financing sales tax). Please consult with your product specialist representative for additional financing options.</i>	



Date : 9/17/2025  
 Quote Expires: 12/31/2025

TO : South San Luis Obispo County Sanitation District  
 1600 Aloha Place  
 Oceano, CA 93445

Telephone : 805-489-6666 ext. 109  
 Attention : Chris Rigoni  
 Quotation : LV09172025  
 Prepared By : Luis Valdez  
 FOB: Delivered



\*unit shown with optional cab\*

Forklifts Group is pleased to have an opportunity to bid on your material handling requirements.

We are pleased to quote you the following new Bobcat Forklift for your consideration.

**Bobcat Forklifts D25S-9 Doosan Diesel 5,000 lb. Capacity, I. C. Pneumatic Tire Forklift**

UL Rating	UL Rated Type D
Brakes	Oil-Cooled Disc Brakes
Drive Tires	Single Drive Soft Solid 7.00-15
Steer Tires	Soft Solid 6.50-10
Mast	3-Stage Full Free Triple High Visibility MFH 189" OAL 86" FFH 60"
Tilt Cylinders	6° Forward / 5° Back
Sideshifter	Integral Sideshifting Fork Positioner 44" Wide
Carriage	Included with Integral Attachment
Forks	Hook Type - Pallet - 1.8" x 4" x 47"
Load Backrest	Included with Fork Positioner
Overhead Guard	Standard Height - 86"
Display	5" Display
Hydraulic Lines	4-Way For Sideshifting Fork Positioner
Hydraulic Control Valve	4 Section with 4 Levers
Seat	Vinyl Suspension Seat with Hip Restraint
Grab Bar	Rear Grab Bar with Horn Button
Warning Lights	Amber Strobe - Mounted Below OHG
Warning Device	Back-Up Alarm (Outside Mount)
Front Work Lights	Front Flood Lights - LED
Rear Work Lights	(1) Rear Flood Light - LED
Exhaust System	Standard Vertical Muffler
Side Panels	Standard Side Panels
Access Control	Key Switch
Fuel Cap	Fuel Cap without Key
Fire Extinguisher	1.5 lb. ABC Type
Warranty	Bobcat Assurance - Standard 2 Year / 3,000 Hour, Powertrain 3 Year / 6,000 Hour, OCDB 5 Year / 10,000 Hour

**Standard Equipment**

**Doosan 2.4L DM02P Tier 4 Diesel Engine**

- Power Shift Transmission
- Power Steering
- Park Brake
- Maintenance Free Battery
- Tilt Steering Wheel
- Dual Element Air Cleaner
- Vertical Exhaust Muffler
- Low Fuel Indicator
- Ground Speed Control
- Interior Tilt Cylinder Covers
- Auto Shift Control
- 12v Aux Power and USB Port
- Cup Holder
- Guardian Stability System
- Heated Secondary Fuel Filter
- Rear View Mirrors - Large



<b>Investment Price:</b>	<b>\$ 50,900.00</b>
<b>Bobcat Factory Rebate (Good through December 31, 2025 only):</b>	<b>- \$5,000.00</b>
<b>Bobcat Competitive Trade In Rebate (Like Model Only)</b>	<b>- \$3,000.00</b>

**Total Price:** **\$42,900.00**

Plus Applicable Taxes

Term: 10% cancellation policy applies.  
 Net on Delivery or finance subject to Credit approval.  
 Special Ordered forklifts require a Deposit of minimum of 10%.

Signed and accepted on behalf of:  
Forklifts Group

Signature: \_\_\_\_\_

Print Name: Luis Valdez

Title: \_\_\_\_\_

Date: \_\_\_\_\_

Luis Valdez  
 luis.valdez@forkliftsgroup.com  
 661-570-7440

Signed and accepted on behalf of:  
South San Luis Obispo County Sanitation District

Signature: \_\_\_\_\_  
(SIGNATURE OF AUTHORIZED OFFICER OR REPRESENTATIVE REQUIRED)

Print Name: \_\_\_\_\_

Title: \_\_\_\_\_

Date: \_\_\_\_\_

South San Luis Obispo County Sanitation District  
 1600 Aloha Place  
 Oceano, CA 93445

Optional (not included in proposal above)  
Credit Application Needed for Exact Pricing

**Finance:** \_\_\_\_\_

**Finance Option 1, PNC – on approval of credit:**

FMV Lease with no purchase, Return at end of term, 1,000 Annual Hours:

36 month, FMV Lease Options:	\$556.45 per month plus tax ea. Initial _____
48 month, FMV Lease Options:	\$449.89 per month plus tax ea. Initial _____
60 month, FMV Lease Options:	\$425.89 per month plus tax ea. Initial _____

**Finance Option 2, PNC – on approval of credit:**

\$1 Buy Out Lease, Own at end of term:

36 month, FMV Lease Options:	\$1 per month plus tax ea. Initial _____
48 month, FMV Lease Options:	\$814.57 per month plus tax ea. Initial _____
60 month, FMV Lease Options:	\$685.09 per month plus tax ea. Initial _____

**Guaranteed Maintenance:** \_\_\_\_\_

60 Month, 1000 Annual Hours: \$300 per Month Plus EA. Initial \_\_\_\_\_

Agreement Terms and Conditions Signed Separately

**Planned Maintenance Agreement:** \_\_\_\_\_

Interval 3 months or 250 Hours: \$125 Flat Rate plus Parts Initial \_\_\_\_\_

**Other:** \_\_\_\_\_

Add a New Doosan Manual Pallet Jack For Only: \$475.00 Plus Tax Ea. Initial \_\_\_\_\_  
Model HPT28-1-06 5,500 lbs. Capacity





**QUOTATION / PROPOSAL TERMS AND CONDITIONS**

Unless otherwise indicated in the proposal, the following terms and conditions are applicable. Terms and conditions of Sale and Service, available on our website, are an integral part of these proposal terms and conditions and all orders are subject to the same. Seller's terms and conditions are subject to change.

**PROPOSAL VALIDITY PERIOD:** Unless otherwise stated, written proposals shall expire automatically seven (7) days after the date appearing on the proposal unless the Seller receives and accepts Customer's order within that period.

**STANDARD TERMS:** Unless otherwise agreed to by the parties in writing, payment terms are Net 10 days from delivery, subject to credit approval. Lease rates are subject to credit approval/documentation. Special order forklifts or equipment require a 25% minimum deposit. Lease payment and/or sale price does not include any applicable tax, surcharges or freight (unless specified). Purchase and lease pricing are subject to change after an accepted order due to 1) tariff surcharge based on the existing federal requirements in force at the time of invoice and 2) inflationary raw material, component, and supply chain issues. If the purchase price of the equipment/material being sold has not been paid in full prior to the delivery of the equipment/material being sold, the Purchaser agrees to execute at the Seller's request all documents necessary to create and perfect a security interest in said equipment/material. Should Customer fail to make payments when due, Seller may enter Customer's premise and repossess the product. In addition, the Customer shall pay any and all expenses and reasonable attorneys' fees incurred in repossessing and storing any product. All overdue amounts are subject to a finance charge of 1.5% per month as permissible in the jurisdiction.

**SHIPMENT:** Unless otherwise stated, all prices for equipment are F.O.B. factory or point of shipment. Partial shipments are fully payable according to the terms of this agreement.

**DELIVERY:** Estimated lead times and delivery dates are based upon Seller's current judgment and are subject to change. Estimated delivery is based on receipt of completed order, approved financial packages, and all terms and conditions being accepted by Customer. Seller will not be responsible for deliveries later than promised due to causes beyond its reasonable control.

**CANCELLATION OR CHANGES:** Accepted orders cannot be canceled, reduced, or revised, or delivery deferred for greater than 30 days, without Seller's written consent with terms that will indemnify Seller of all losses, costs and expenses. With cancellation, a minimum 25% cancellation fee may be charged to be paid immediately to Seller, along with other losses incurred.

**MISCELLANEOUS:** Customer represents that it shall possess and will maintain all applicable and required permits, licenses, approvals, registrations, consents and certificates. Other financing options and terms may be available (including financing sales tax). Please consult with your product specialist representative for additional financing options.

**ENTIRE AGREEMENT:** This writing and the Seller's Terms and Conditions of Sale and Service constitute the entire agreement between the parties. Seller shall not be bound by any terms of Customer's purchase order which provide conditions additional to or different from the terms hereof. Any modification must be made in writing and approved by both parties. If the terms of this proposal conflict with the Seller's Terms and Conditions of Sale and Service, these Terms shall control.



# SOUTH SAN LUIS OBISPO COUNTY SANITATION DISTRICT

Post Office Box 339, Oceano, California 93475-0339  
1600 Aloha Oceano, California 93445-9735  
Telephone (805) 489-6666 FAX (805) 489-2765  
www.sslocsd.org

---

Staff Report

**To:** Board of Directors  
**From:** Jeremy Ghent, District Administrator  
**Via:** Mychal Jones, Plant Superintendent  
**Date:** June 3, 2026

**Subject: REQUEST APPROVAL TO PURCHASE RECLAIM WATER  
FILTRATION SYSTEM**

**RECOMMENDATION:**

1. That the Board of Directors approve and authorize the District Administrator to purchase a new reclaim water filtration system in the amount of \$56,259.98; and
2. Authorize staff to surplus and dispose of the existing reclaim water filtration system.

**BACKGROUND AND DISCUSSION:**

The District budgeted for the purchase and replacement of the existing reclaim water filtration system in the current fiscal year. The existing system has reached the end of its useful service life and requires replacement. Replacement of the system will help ensure the continued reliability and performance of the District's reclaimed water operations. Staff is requesting approval to purchase a replacement filtration system and authorization to dispose of the existing unit.

Because the proposed Amiad Water Systems SAF-X-3000 filtration system is a direct replacement, is proprietary in nature, and is compatible with the existing plumbing and electrical infrastructure, a sole-source quote was obtained for this purchase. The quote submitted by Amiad Water Systems in the amount of \$56,259.98 meets the District's operational requirements and specifications.

**FISCAL CONSIDERATION:**

Adequate funding was included in the adopted Fiscal Year 2025/26 Budget under Fund 26, Account No. 26-8065.

**Attachment:**

Quote

### Filter System Quotation

To: So. San Luis Obispo Sanitation Dist. C/O JBI Water & Wastewater	Date: 05/26/2026
Attn: Mike Arias (Simon Morris, JBI)	Page: 1 of 1
Phone: 805-489-6666	Quote #: JBI-SAF-X-3000-032826-C2
Fax:	Job Name: South SLO County Sanitation District, CA
E-mail: <a href="mailto:arias@sslocsd.us">arias@sslocsd.us</a> <a href="mailto:simonmorris@biwater.com">simonmorris@biwater.com</a>	JB Water

#### Information Required for Detailed Quotation:

System Flow Rate: Please provide information	Min. Flow for Flushing: 62 gpm
Line Size: 4"	
System Operating Pressure: Please provide information	<b>Minimum: 30 PSI</b> Maximum: 150 PSI
System Operating Temperature: Please provide information	<b>During Backwash</b> Maximum: 120°F
Water Source: <b>Please provide information</b>	Water Use: Please provide information
Stated TSS: Please provide information	
Filtration Degree Desired: 50 µ	
Power Source: Please provide information	
Description of Application: <b>Replace existing 2 x SAF filters with new SAF-X series (serial #10-11-100011423).</b>	
<b>Design Description:</b>	
Construction: <i>Housing Material</i> : Epoxy Coated Carbon Steel	<i>Screen Material</i> : Stainless Steel 316L
Special Features:	

#### Filter System Option(s): 2 x 4" SAF-X-3000 filters

Item	Quantity	Part Number and Description	Net Price
1	2	4" SAF-X-3000 automatic self-cleaning filter, <i>carbon steel body</i> , epoxy-coated exterior and interior, with spring-loaded suction scanner nozzles, with 2" electric flush valve (Bray Series 31 butterfly valve with S70/120V AC electric actuator), with a DP switch and a Baldor motor	\$ 35,209.00 ✓
2	2	50 - micron SAF-X-3000 Screen Element, 316L stainless steel, weave-wire	Included
3	1	AML2+ controller to control both strainers, UL listed, 480V AC, 3-Phase, 60 Hz (or other customer specified) power supply, Allen Bradley PLC & HMI, power and control to electric flush valve, with dry contact output for filter flush in progress and fault, with input for remote start/stop, with service disconnect junction box for each strainer for easy maintenance.	\$ 11,772.00 ✓
<b>TOTAL NET PRICE</b>			<b>\$ 46,981.00</b>

#### Optional Cost Adders:

##### On-site services:

			Unit Net Price	Extended Net price
4	1	<b>On-Site Services of qualified technical representative</b>	Standard daily labor rate (8 hours per day)	\$ 1,500.00 \$ 1,500.00 ✓
	TBD		Remote support hourly rate	\$ 125.00
	1		Standard daily travel rate (including other miscellaneous and travel related expenses)	\$ 1,000.00 \$ 1,000.00 ✓

**1 additional year of the extended warranty will be provided if startup services are purchased and performed by Amiad-qualified technical personnel.**

#### Spare parts (SAF-X-3000 Screen Filter System)

5	TBD	<b>Annual Preventive Maintenance Kits</b>	1. Spare Parts Kit (Suction Scanner Assembly):	See next page
6	TBD	<b>Capital Spare Parts</b>	2. Highly Recommended "On the Shelf" Critical Spare Parts:	See next page
7	TBD		3. Recommended "On the Shelf" Spare Parts:	See next page

**Spare part kits prices include additional 15% discount if purchased with the filter/system**

#### Technical notes:

1. A non-return check valve is required at the outlet of each filter. **Back surge will damage the filter.**
2. Flushing according to pressure differential or time interval.
3. Flushing line should have no interruption on flow and minimum restriction.

#### Commercial notes

1. Prices are valid for thirty (30) days from date of issue.
2. Freight charges will be added to total price at the time of order.
3. Should the underlying cost factors of this price offer (including tariffs, raw material prices, currency exchange rates, labor costs, transport costs, and other duty costs) change between the date of this offer and the time of the order, Amiad Water Systems reserves the right to revise the offered prices in light of these changing cost factors
4. Amiad's standard Terms and Conditions will apply to all orders. A copy of these Terms and Conditions can be obtained in the link below.  
[USA-Terms-and-Conditions.pdf](#)

FOB Shipping Point: Mooresville, NC

Terms of Payment: Net 30 days

Delivery: 10-12 weeks

Please feel free to contact me or your Representative for additional details, questions, or comments.

Regional Sales Mgr.: Dan Inman

Phone Number: (303) 506 1418

E-mail: [dan.inman@amiad.com](mailto:dan.inman@amiad.com)

**Thank you for choosing Amiad Filtration Systems, we provide clear solutions to your water filtration problems.**

Best regards,  
Helti Perera  
Applications Engineer

## Recommended Spare Parts List

### SAF-X-3000 Filter with SLN Suction Scanner

Item #	Qty.		Part Number	Description	Unit Price	Total Net price
		Annual Preventive Maintenance Kits	<b>1. Spare Parts Kit (SLN Suction Scanner Assembly)</b>			
	1		700194-000008	Annual Preventive Maintenance Kit	\$ 355.00	\$ 355.00

Item #	Qty.		<b>2. Highly Recommended "On the Shelf" Critical Spare Parts:</b>			
	1		710103-002117	Bearing SAF POM Flush Chamber	\$ 46.00	\$ 46.00
	1		760105-000098	Dowel Pin 6 x 36 MM S/ST316	\$ 15.00	\$ 15.00
	1		710103-002501	Plug 8mm SAF POM F/Scanner	\$ 23.00	\$ 23.00
	1		710103-002237	Key SAF Brass F/Drive Shaft	\$ 31.00	\$ 31.00
	2		720302-000004	Limit Switch Pizzato NC	\$ 77.00	\$ 154.00
	1		720104-000028	DP Switch	\$ 455.00	\$ 455.00
	1		720203-000128	Motor 1/4 HP Baldor TEFC 460V AC/3-Ph	\$ 855.00	\$ 855.00

Item #	Qty.		<b>3. Recommended "On the Shelf" Spare Parts:</b>			
	1		720202-000019	GEAR RMI50 63 B5 1/28 SITI MT-5010	\$ 348.00	\$ 348.00
	1		700101-002436	50 Micron Weave-wire Screen Element	\$ 1,480.00	\$ 1,480.00

*Thank you for choosing Amiad Filtration Systems, we provide clear solutions to your water filtration problems.*

Item Summary					
Line Item	Part Number	QTY.	Description	NET PRICE	
				\$	
1	2x4" SAF-X-3000	2	SAFX 3000 Filters	35,209.00	
	50 mic-SAF-X-3000-316L				
2	screen	2	50-micron screens	incl.	
	AML2+ dual				
	480V, 3-ph,			\$	
3	60Hz. AB PLC	1	AML2+ dual controller	11,772.00	
				\$	
4	Factory Startup	1	Travel & Startup. 1 day ea.	2,500.00	
				\$	
5	700194-000008,	2	Annual PM Kits (\$355 ea,)	710.00	
	760105-000098,			\$	
6	710103-002237	1 ea	dowel pin, brass key	46.00	
				\$	
7	700101-002436	1	50-micron screen, extra	1,480.00	
				\$	
8	Tax	1	7.25%	3,749.48	
			shipping / freight to	\$	
9	Freight	1	jobsite	793.50	Uli quoted
				\$	
<b>Total</b>				<b>\$56,259.98</b>	

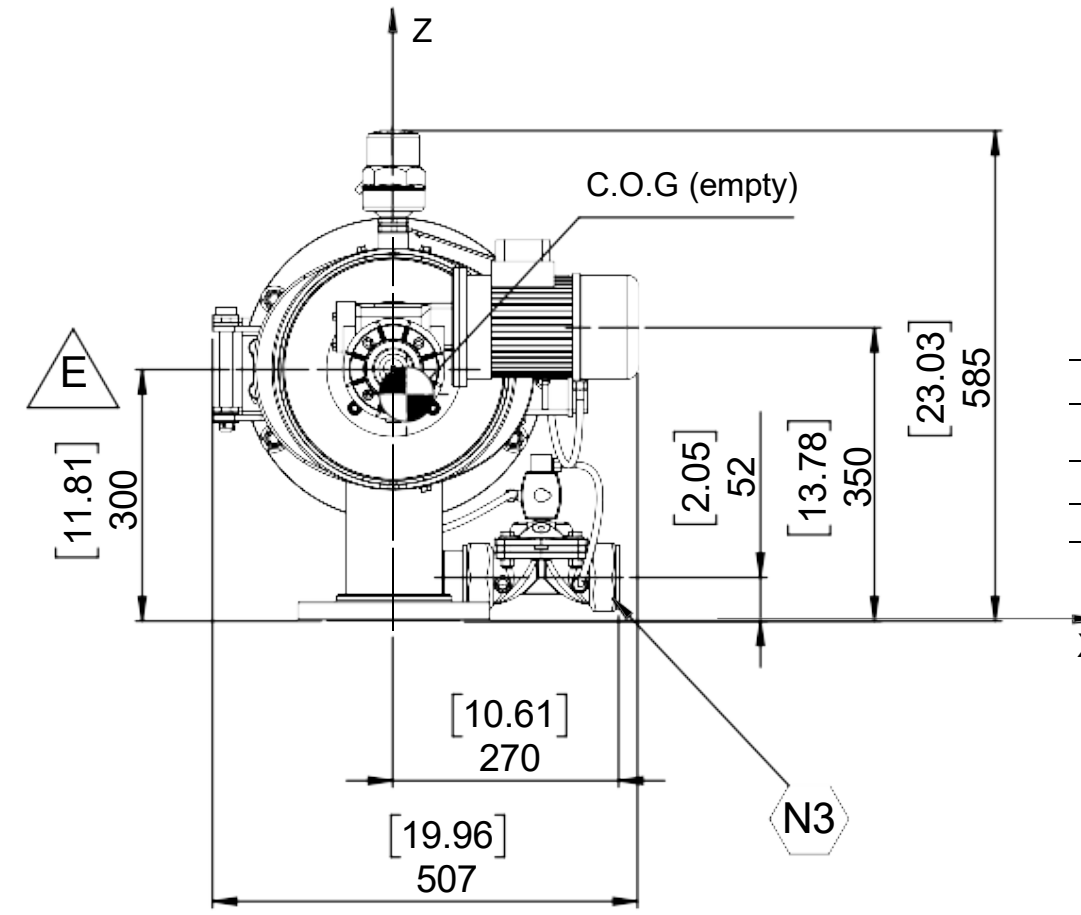
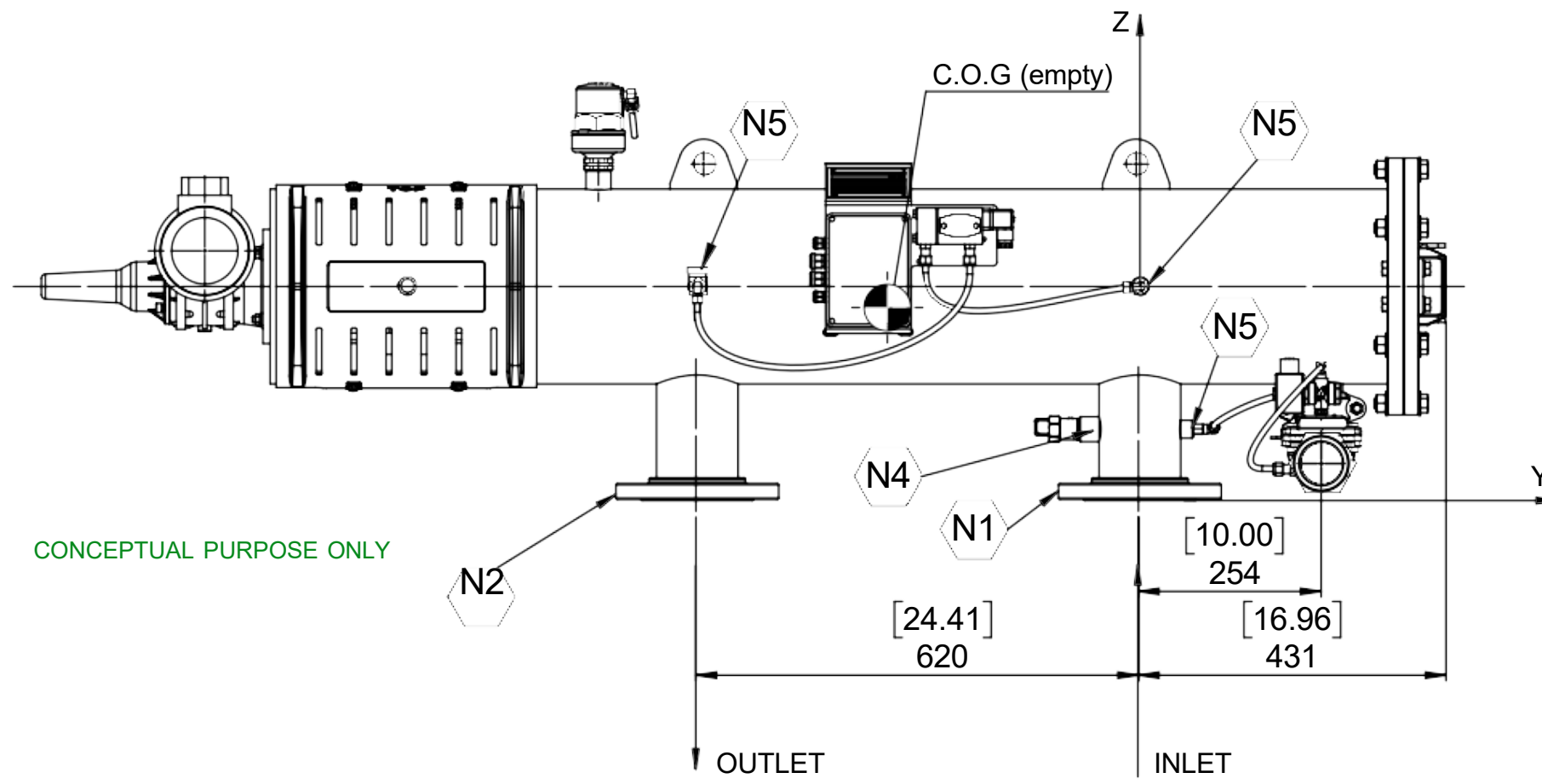

CONCEPTUAL PURPOSE ONLY

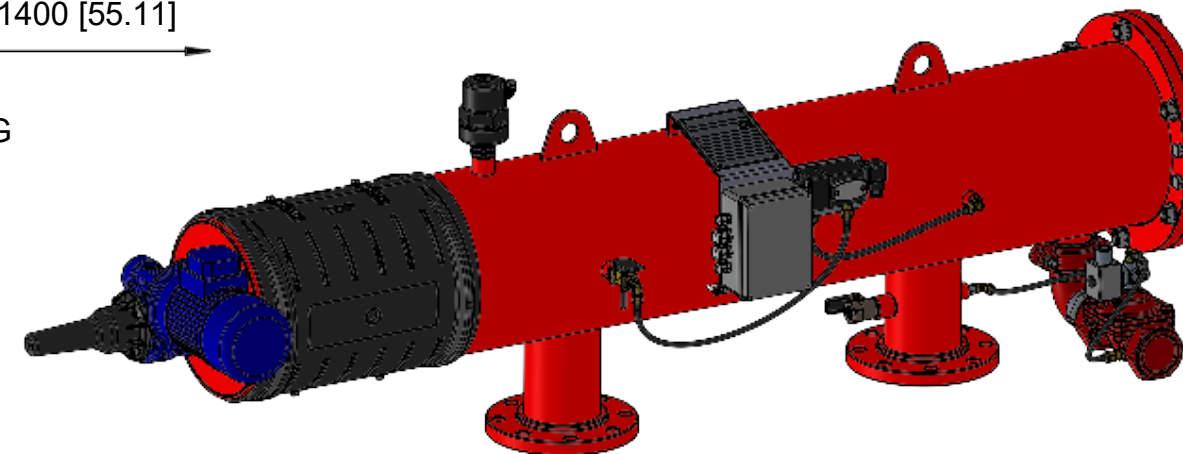
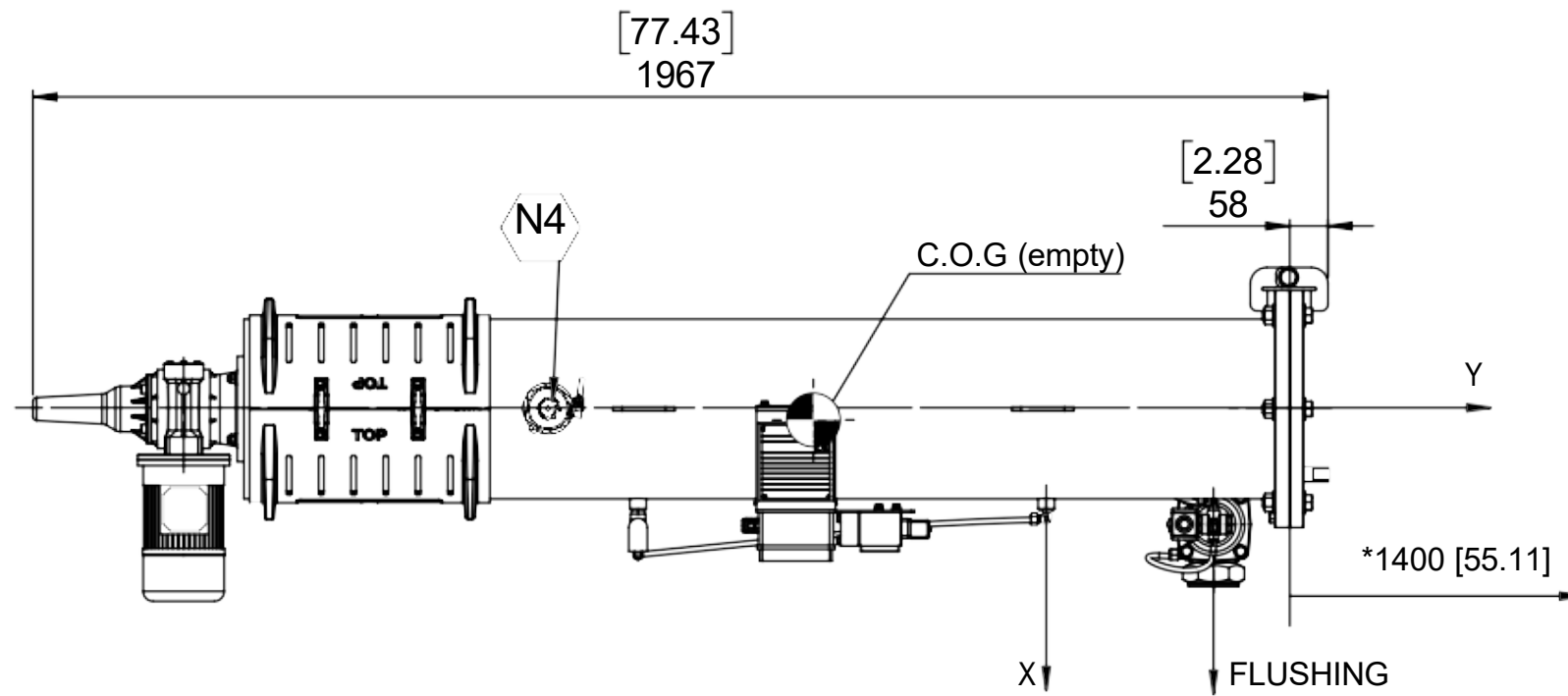

\* APPROX. LENGTH REQUIRED FOR MAINTENANCE.  
DIMENSIONS ARE IN MM [INCH]

LINEAR GENERAL TOLERANCES (mm)

DIMENSIONS	0.5-3	>3-50	>50-120	>120-400	>400-1000	>1000
TOLERANCE	±0.5	±1	±1.5	±2.5	±4	±6

NOZZLES LIST

CODE	QTY.	DN	CLASS	PIPE	CONNECTION	SERVICE
N1	1	4"	BY DEMAND	VARY	S.O.R.F	INLET
N2	1	4"	BY DEMAND		S.O.R.F	OUTLET
N3	1	2"	BSP		Thread (F)	FLUSHING
N4	2	3/4"	BSP		Thread (F)	Drain / Air release
N5	3	1/4"	BSP		Thread (F)	INSTRUMENTATION

CONSTRUCTION

Materials For Filter Vessel  
Housing / Lid: C/ST  
Flanges: See Class

DESIGN CRITERIA

Design Code	EN-13445
Design Pressure	10 Bar [ 145psi]
Design Temperature	50°C [*122 F]
Volume	65 L / 17.2 Gallons

TOTAL WEIGHT

	KG	LB
Empty	121	267
Operating	181	399
Lid	16	35

CENTER OF GRAVITY mm [Inch]

	X	Y	Z
Empty	22.3[0.92]	-352.8[-12.7]	269.4[10.34]
Operating	22.1[0.89]	-331.4[-14.1]	271.3[12.5]

Date	Reason for Issue	By	Chk	Apr
E 05.02.2024	DIM.ADDED	A.S.	I.Z.	I.Z.
C 18.09.2022	volume of filter changed to 65	A.S.	I.Z.	I.Z.
A 17/10/2021	FIRST ISSUE	E.G.	I.Z.	I.Z.

REVISION



PROJECT :

4" SAF-X 3000 FILTER

TITLE :

4" SAF-X 3000 FILTER

Cat. No.:	SCALE (A2):	REV.:
	1:8	E

Drw. No.:	SHEET NO.1 OF 1
DRW-0000052729	

Confidential property information.  
Amiad Water Systems Ltd. Reserves the rights to make changes.  
All copy rights reserved to Amiad Water Systems Ltd.

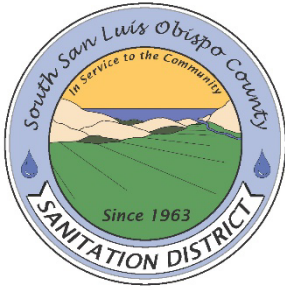

## **SOUTH SAN LUIS OBISPO COUNTY SANITATION DISTRICT**

Post Office Box 339, Oceano, California 93475-0339  
1600 Aloha Oceano, California 93445-9735  
Telephone (805) 489-6666 FAX (805) 489-2765  
[www.sslocsd.org](http://www.sslocsd.org)

---

### **Staff Report**

**To:** Board of Directors  
**From:** Jeremy Ghent, District Administrator  
**Via:** Mychal Jones, Plant Superintendent  
**Date:** June 3, 2026

**Subject: PUBLIC HEARING TO CONSIDER ENTERING INTO ENERGY SERVICE  
CONTRACT PURSUANT TO GC 4217**

#### **RECOMMENDATION:**

Continue to July 1, 2026, Board Meeting.

#### **DISCUSSION:**

The District Noticed a Public Hearing in accordance with California Government Code 4217. Staff had intended to present to the Board, and the public, the framework of terms and conditions of an Energy Services Agreement with Southland Industries to deliver a turnkey cogeneration system. This system would utilize wasted biogas to generate power and heat to offset the majority of the treatment plants energy needs.

District legal counsel has undertaken a review of the agreement. This project represents the District's first design-build project. The District has not previously negotiated the terms and conditions for a design-build project and as such the legal review is more involved.

Staff intend to return at the July 1<sup>st</sup> meeting with a draft agreement that is in a presentable form.

The continued item will be heard on July 1<sup>st</sup> at the Oceano Community Services District, 1655 Front St, Oceano CA 93445

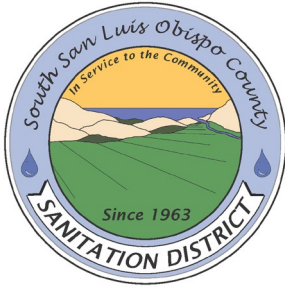

# SOUTH SAN LUIS OBISPO COUNTY SANITATION DISTRICT

Post Office Box 339, Oceano, California 93475-0339  
1600 Aloha, Oceano, California 93445-9735  
Telephone (805) 489-6666 FAX (805) 489-2765  
[www.sslocsd.org](http://www.sslocsd.org)

---

## Staff Report

**Date:** June 3, 2026  
**To:** Board of Directors  
**From:** Jeremy Ghent, District Administrator

**Via:** Mychal Jones, Plant Superintendent; and Amy Simpson, Business & Accounting Analyst

**Subject:** **2026/27 FISCAL YEAR BUDGET; SET PUBLIC HEARING FOR JULY 1, 2026.**

### **RECOMMENDATIONS:**

1. That the Board Provide Input Regarding the Proposed 2026-27 Fiscal Year (FY) Budget and,
2. Set a Noticed Public Hearing for July 1, 2026.

### **DISCUSSION:**

A draft of the District Budget for Fiscal Year 2026-27 is attached. This budget covers the period of July 1, 2026, to June 30, 2027. Currently the District has a combined cash reserve of \$13,500,066 as of May 2026.

This fiscal year the District will expend all annual revenues and will program either \$9,407,345 or \$1,732,345 in reserves to meet the operational, maintenance and capital needs of the District. The two different numbers represent advancing The FY 2026/27 Budget includes costs associated with operating the expanded facility post Redundancy. The FY 2026/27 Operation expenses are 4.74% higher than those of the previous fiscal year. The 4.74% increase is due to increases in labor, staffing, benefit costs and increased maintenance on the trunk sewer mains.

FY 2026/27 will focus on pursuing cogeneration energy savings, cleaning of our # 1 Digester, cleaning and inspecting 9 miles of District trunk mains, and conducting a plantwide condition assessment.

Using past experiences and best professional judgement, the draft budget for fiscal year 2026-27 was prepared using conservative estimates and assumptions, mindful of the need to operate the facility in a safe, cost effective, efficient manner while complying with applicable federal, state and

local requirements. Revenue values for wastewater and connection fees were projected based on past revenues.

Tabulated below are summary values extracted from the Consolidated Budget.

**Consolidated Budget**

Revenues by Fund Source

	Fund 19	Fund 20	Fund 26	Totals
Total Revenues	\$ 7,153,000	\$ 175,000		\$ 7,328,000
Use of Reserves	\$ 1,732,345	\$ 7,675,000		\$ 9,407,345
<b>Total Revenues</b>	<b>\$ 8,885,345</b>	<b>\$ 7,850,000</b>		<b>\$ 16,735,345</b>

Expenditures by Fund Source

Total Operating Expenditures	\$ 4,917,345			\$ 4,917,345
Total Capital Outlay	\$ -	\$ 7,850,000		\$ 7,850,000
Debt Service	\$ 1,230,000			\$ 1,230,000
Operating Transfers Out/In	\$ 2,738,000		\$ 2,738,000	\$ 2,738,000
<b>Total Expense</b>	<b>\$ 8,885,345</b>	<b>\$ 7,850,000</b>	<b>\$ (2,738,000)</b>	<b>\$ 16,735,345</b>

Balanced Budget	\$ -	\$ -	\$ -	\$ -
-----------------	------	------	------	------

**Fund 19**

Fund 19 revenues are primarily wastewater service charges collected from Arroyo Grande, Grover Beach and Oceano. Other revenues are primarily generated from brine disposal with minor contributions from lease payments and other reimbursements.

Fund 19 supports the following general categories of District activities:

- Salaries and Wages
- Employee Benefits & Other Personnel Costs
- Permits, Fees and Licenses
- Communications and Computer Support
- Administrative Costs, including Professional Services – Advertisements/Recruitment, Insurance Liability, Public Outreach
- Legal Costs
- Engineering
- Coastal Hazards & Monitoring
- LAFCO Budget Share
- Zone 1/1A Agreement
- Agency Billing
- Disposal Services – Solids Handling, Brine Disposal Sampling
- Utilities – Electricity, Gas, Rubbish, Water
- Maintenance, Tools & Replacements – Equipment and Structures Maintenance
- Materials, Services and Supplies – Plant Chemicals, Temporary Labor, Fuel
- Training, Education and Memberships – Professional Certificates/Licenses
- Maintenance, Tools, and Replacements
- New Capital Equipment
- Transfer out of Fund 19 funds to support Fund 26 Projects - \$2,738,000

Staffing

The staff roster consists of a District Administrator (1), Business & Accounting Analyst (1), Plant Superintendent (1), Plant Operations Supervisor (1), Plant Senior Operator (1), Laboratory Manager (1), Laboratory Technician (1), Plant Operator II (4). There continue to be eleven (11) full-time positions funded in the draft budget.

**Fund 20**

Fund 20 revenue is provided primarily from connection fees from the three-member agencies. A minor amount of revenue is received from interest on the fund balance account.

This fund supports capacity, expansion, and studies.

The Cogeneration project is a tentative project being considered by the District. If approved later during FY 2026/27, the District will evaluate taking on debt to fund or partially fund the project.

<b>20-8010 Capital Equipment</b>	
Cogeneration Unit	<u>7,850,000.00</u>
<b>Total 20-8010 Capital Equipment</b>	7,850,000.00

**Fund 26**

Fund 26 expenditures are wholly supported by transfers from other funds. The draft budget calls for a transfer from Operating Fund 19 to Replacement Fund 26 which funds regular capital replacement projects.

Proposed Fund 26 Project Budgets:

- Account 26-8065 - Structure/Grounds Replacement & Improvement - \$2,738,000

<b>26-8065 Struct/Grounds Replace</b>	
Amiad Filter Replacement	75,000.00
Condition Assessment	570,000.00
Digester No. 1 Cleaning & Rehab	1,500,000.00
Lawnmower	15,000.00
Operator Cart	18,000.00
Primary Sludge Pump No. 3	40,000.00
Trunk Sewer Cleaning Inspection	400,000.00
Work Vehicles (2)	120,000.00
<b>Total 26-8065 Struct/Grounds Replace</b>	<u>2,738,000.00</u>

## Fund 26 Project Descriptions

- **Amiad Filter Replacement**

The existing system has reached the end of its useful service life and requires replacement. Replacement of the system will help ensure the continued reliability and performance of reclaimed water operations. Reclaimed water is used throughout the plant for various processes. This item is carried over from the adopted 2025/26 Fiscal Year budget. Due to a long lead time in receiving this equipment, Staff is carrying over this budgeted item into the 2026/27 Fiscal Year budget. The estimated cost includes equipment purchase, installation, and associated electrical and mechanical modifications as required.

- **Condition Assessment**

Staff developed a robust Condition Assessment Project which incorporates the FFR Rehab Planning and Structural Inspections included in the 2025/26 Fiscal Year budget. This effort, which is carrying over to the 2026/27 Fiscal Year budget, will provide a systematic evaluation of the structural, mechanical, electrical, and process condition of treatment facilities, identify near-term deficiencies and vulnerabilities, and quantify the short-, mid-, and long-term capital investments required to maintain the plant at its current location. Importantly, the plan would distinguish between investments necessary to sustain existing infrastructure versus those that would extend the useful life of the plant in a regulatory and environmentally constrained setting.

The resulting planning document would serve as a critical decision-making tool for the District, enabling an informed comparison between costs, risks, and regulatory constraints associated with continued operation at the existing site and the potential costs and benefits of relocating the treatment facility. It would also position the District to respond proactively to upcoming CDP reevaluation milestones by providing clear, defensible documentation of infrastructure needs, long-term risks, and strategic options. Proposals were received on May 20th with a Notice to Proceed expected July - August 2026 following Board approval.

- **Digester No. 1 Cleaning & Rehab**

10-year routine scheduled maintenance of Digester No. 1. This project consists of draining and cleaning of the entire digester and associated appurtenances, thorough inspection once empty, and any repairs and rehabilitation necessary following inspection.

Over time, non-digestible heavy solids accumulate inside the digester, reducing the usable volume for beneficial bacteria and lowering treatment efficiency. If left unaddressed, this accumulation can cause mechanical damage to mixers, lead to odor issues, and reduce vital treatment capacity to meet regulatory requirements. Regular cleaning and rehabilitation prevent unexpected failures and help the District's facility comply with its permit requirements.

- **Lawnmower**

The existing lawnmower has reached the end of its useful service life and requires replacement. Replacement of the lawnmower will ensure the continued maintenance and landscaping of the treatment facility grounds.

- **Operator Cart**  
The existing utility cart has reached the end of its useful service life and is no longer reliable for daily operations. Replacing the cart is necessary to support the efficient transport of tools, equipment, and materials throughout the wastewater treatment plant, helping staff perform maintenance and operational tasks safely and effectively.
- **Trunk Sewer Cleaning and Inspection**  
Trunk Sewer Cleaning and Inspection Project is to document the condition of the District's trunk sewer system. This project includes the cleaning of the entire District trunk sewer system, Closed-Circuit Television (CCTV) inspection of the entire trunk sewer system, evaluate and grade sewer condition using an approved coding system to document conditions/defects, manhole inspections and record using an approved coding system to document conditions/defects, and any additional services that would supplement the cleaning and condition assessment objectives. The final inspection report will be evaluated to develop an updated capital improvement plan with recommended prioritization, budgetary costs, and schedule.
- **Work Vehicles (2)**  
This budget item provides for the replacement of two utility work vehicles that have reached the end of their useful service life and are experiencing increasing maintenance and repair costs. The new vehicles will support daily operations by transporting personnel, tools, equipment, and materials, improving reliability, safety, and operational efficiency while reducing downtime and long-term fleet maintenance expenses.
- **Primary Sludge Pump No. 3**  
The existing sludge pump has reached the end of its useful service life and requires replacement. The new sludge pump will support efficient transfer and processing of sludge, helping maintain regulatory compliance, operational efficiency, and system reliability while reducing the risk of equipment failure, service disruptions, and ongoing maintenance costs. The estimated cost includes equipment purchase, installation, and associated electrical and mechanical modifications as required.

## **Conclusion**

The draft budget emphasizes maintenance and operation of the existing plant, maintenance and repairs to the trunk sewer system, pursuing cogeneration energy savings, cleaning of our # 1 Digester, cleaning and inspecting 9 miles of District trunk mains, and conducting a plantwide condition assessment.

District revenues and planned rates continue to meet operations, maintenance, capital replacement, and debt service needs of the District.

## **Attachments:**

- Attachment 1: Consolidated Budget
- Attachment 2: Notice of Public Hearing

## CONSOLIDATED BUDGET FY 2026/27

		Fund 19 Operating Fund	Fund 20 Expansion Fund	Fund 26 Replacement Fund	Proposed Budget FY 2026/27
<b>Revenues</b>					
Service Charges and Fees		6,744,000			6,744,000
Connection Fees			75,000		75,000
Interest		309,000	100,000		409,000
Brine Revenue		100,000			100,000
<b>Revenues</b>		<b>7,153,000</b>	<b>175,000</b>		<b>7,328,000</b>
Use of Reserves		1,732,345	7,675,000		9,407,345
<b>Total Revenues</b>		<b>8,885,345</b>	<b>7,850,000</b>		<b>16,735,345</b>
<b>Expenditures &amp; Other Uses</b>					
Operating Expenditures					
Salaries and Wages		1,295,395			1,295,395
Employee Benefits and Other Personnel Costs		825,300			825,300
Permits, Fees and Licenses		66,000			66,000
Communications		21,000			21,000
Administrative Costs		349,150			349,150
Legal Costs		60,000			60,000
Engineering		100,000			100,000
Coastal Hazards & Monitoring		80,000			80,000
LAFCO Budget Share		19,000			19,000
Zone 1/1A Agreement		40,000			40,000
Agency Billing		75,000			75,000
Disposal Services		105,000			105,000
Utilities		595,000			595,000
Maintenance, Tools & Replacements		447,000			447,000
Materials, Services and Supplies		732,000			732,000
Training, Education & Memberships		47,500			47,500
Supervisory Control & Data Acquisition		60,000			60,000
<b>Total Operating Expenditures</b>		<b>4,917,345</b>			<b>4,917,345</b>
<b>Total Other Charges</b>					
Debt Service		1,230,000			1,230,000
<b>Total Other Charges</b>		<b>1,230,000</b>			<b>1,230,000</b>
<b>Capital Outlay</b>					
Capital Replacement/Maintenance (Fund 26)				2,738,000	2,738,000
Capital Equipment		-	7,850,000		7,850,000
<b>Total Capital Outlay</b>		<b>-</b>	<b>7,850,000</b>	<b>2,738,000</b>	<b>10,588,000</b>
<b>Other Financing Sources &amp; Uses</b>					
Transfers Out/In Fund 26		2,738,000			2,738,000
<b>Total Other Financing Sources &amp; Uses</b>		<b>2,738,000</b>		<b>-</b>	<b>2,738,000</b>
<b>Total Funding Source</b>					
Total Funding Source		8,885,345	7,850,000		16,735,345
<b>Total Expense</b>					
Total Expense		8,885,345	7,850,000		16,735,345
<b>Net Change (Deficit)</b>		<b>-</b>	<b>-</b>	<b>-</b>	<b>-</b>

Balanced Budget

**NOTICE OF PUBLIC HEARING  
SOUTH SAN LUIS OBISPO COUNTY  
SANITATION DISTRICT  
ADOPTION OF FISCAL YEAR 2026-2027 BUDGET**

**DATE:** July 1, 2026  
**TIME:** 6:00 p.m.  
**PLACE:** Arroyo Grande Council Chambers  
215 E. Branch Street,  
Arroyo Grande CA

**PLEASE TAKE NOTICE:**

1. The District Administrator has prepared a proposed Final Budget, which is available for inspection, during regular business hours, 7:30 a.m. to 4:00 p.m., Monday through Friday, at the District Office located at 1600 Aloha Place, Oceano, California.

At 6:00 p.m., on July 1, 2026, South San Luis Obispo County Sanitation District Board of Directors will meet to consider and to adopt the final Fiscal Year 2026-2027 Budget.

2. At the time and place specified in this Notice, any person may appear to be heard regarding any item in the Budget or regarding the addition of any other items.
3. The hearing on the Budget may be continued if necessary.

If you should have questions related to the Budget, please contact Amy Simpson, Business & Accounting Analyst, at (805) 481-6903.

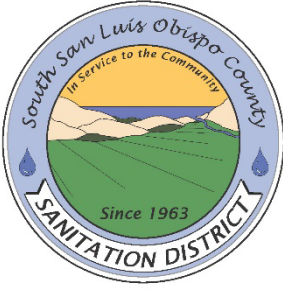

# SOUTH SAN LUIS OBISPO COUNTY SANITATION DISTRICT

Post Office Box 339, Oceano, California 93475-0339  
1600 Aloha Oceano, California 93445-9735  
Telephone (805) 489-6666 FAX (805) 489-2765  
[www.sslocsd.org](http://www.sslocsd.org)

---

## Staff Report

**To:** Board of Directors  
**From:** Jeremy Ghent, District Administrator  
**Via:** Mychal Jones, Plant Superintendent  
**Date:** June 3, 2026

**Subject: REQUEST APPROVAL TO PURCHASE FLOW AND LEVEL MONITORING EQUIPMENT**

### **RECOMMENDATION:**

1. That the Board of Directors approve and authorize the District Administrator to purchase new flow and level monitoring equipment in the amount of \$31,746.

### **BACKGROUND:**

In April 2026, the District completed a trunk sewer capacity study to evaluate the ability of the District's trunk sewer collection system to accommodate existing and future wastewater flows over a 20-year planning horizon. The study evaluated system capacity constraints, inflow and infiltration (I/I), and the overall condition of the collection infrastructure. The study also identified future collection system needs, recommended required upgrades, and developed a Capital Improvement Plan (CIP) for implementation over the planning horizon.

As part of the study, updated flow monitoring was conducted because the District's previous flow monitoring study was completed nearly 15 years ago. The updated monitoring effort was used to estimate current flow conditions for each member agency, validate hydraulic model assumptions, establish peaking factors, and identify areas potentially impacted by I/I during wet weather conditions. Three separate monitoring sessions were conducted to establish baseline dry weather flows, capture peak seasonal dry weather flows, and evaluate wet weather conditions.

Peak hour flow (PHF) represents the highest one-hour wastewater flow to the District's wastewater treatment plant and is used to evaluate the system's ability to accommodate short-duration peak flows without pipeline surcharging or sanitary sewer overflows (SSOs). Because the wet weather monitoring period did not capture a significant storm event, two peak flow scenarios were developed to evaluate a range of potential future conditions:

- Peak Hour Flow, Scenario 1 (PHF-1) – Peaking factors based on observed flow meter data collected during wet weather monitoring.

- Peak Hour Flow, Scenario 2 (PHF-2) – Peaking factors based on industry literature correlating service population to peak flow conditions.

Under a future PHF-2 scenario, which assumes approximately 17% population growth and a total system flow of 5,491 gallons per minute (gpm), multiple pipeline segments were projected to exceed the District's design criterion of 75% depth-over-diameter ratio (d/D).

The d/D ratio is used to evaluate the fullness of a pipeline. For example, a d/D ratio of 50% indicates a pipe is half full, while 100% indicates a completely full pipe. Elevated d/D ratios may indicate flow restrictions or insufficient pipe capacity during peak flow conditions. Insufficient capacity can result in backwater conditions and increase the potential for sanitary sewer overflows.

No deficiencies were identified under average daily flow conditions or existing peak hour flow conditions. Capacity concerns were limited to the future peak hour flow scenario.

### **DISCUSSION:**

Based on the findings and recommendations of the capacity study, Staff recommends purchasing new trunk sewer flow and level monitoring equipment in the amount of \$31,746.

The proposed equipment consists of six permanent monitoring units supplied by Consibio. Staff reviewed available monitoring equipment vendors and determined Consibio best met the District's operational and compatibility needs. Three units will monitor flow, level, and velocity and will be installed in identified areas of concern. One unit will replace an existing level monitoring unit located at a low-lying manhole adjacent to an environmentally sensitive area. Two additional units will monitor groundwater levels at the wastewater treatment facility.

The proposed equipment will improve the District's ability to continuously monitor system performance, collect real-time flow data, identify potential inflow and infiltration issues, and support future planning and capital improvement efforts. The equipment will also improve operational awareness during wet weather events and future peak flow conditions.

### **FISCAL CONSIDERATION:**

Adequate funding was included in the adopted Fiscal Year 2025/26 Budget under Fund 26, Account No. 26-8065. Additional funding for ongoing cellular connectivity and cloud-based data services will be included in future budget cycles.

### **Attachment:**

Quotes

# ESTIMATE

**Consibio Inc**  
875 N Michigan Ave  
Ste 3950  
Chicago, IL 60611-1803

sales@consibio.com  
+1 (800) 594-5931  
www.consibio.com



**Bill to**  
Mychal Jones  
South San Luis Obispo County Sanitation  
District  
1600 Aloha Place  
Oceano, California 93445 US

**Ship to**  
Mychal Jones  
South San Luis Obispo County Sanitation  
District  
1600 Aloha Place  
Oceano, California 93445 US

### Estimate details

Estimate no.: 112271  
Estimate date: 05/28/2026

#	Product or service	SKU	Description	Qty	Rate	Amount
1.	<b>Wastewater Pack Advanced Flow</b>	202010	Includes: Consibio Datalogger WD-68 Installation bracket VEGA C21 Radar Pulsar MicroFlow Surface Velocity Radar 2 extra batteries for on-site swap Eyebolt + carabiner	3	\$6,999.00	\$20,997.00
2.	<b>Wastewater Pack Water level &amp; flow</b>	202008	Includes: Consibio Datalogger WD-68 VEGA C21 Radar 2 extra batteries for on-site swap Foldable mounting bracket	1	\$3,495.00	\$3,495.00
3.	<b>Logger 4WD (w. int. antenna)</b>	112012	Delivered with: 2 x Rechargeable Li-ion (48Wh each) 1 x Battery Charger	2	\$1,388.00	\$2,776.00
4.	<b>Vegawell 52</b>		With Ceramic cell - 6 meter cable	2	\$1,244.00	\$2,488.00
5.	<b>Product Discount</b>	991000	Custom discount - authorized by SBF	1	-\$2,100.00	-\$2,100.00
6.	<b>Consibio Cloud &amp; Cellular Network (Yearly)</b>	102001	Unlimited Cloud usage & SIM-card/cellular connection. Price pr. datalogger pr. year	6	\$299.00	\$1,794.00
7.	<b>Shipping Costs (large parcel)</b>	102016	Standard DDP Shipping	1	\$150.00	\$150.00
					Subtotal	\$29,600.00
					Sales tax	\$2,146.00

---

<b>Total</b>	<b>\$31,746.00</b>
--------------	--------------------

---

Accepted date

Accepted by



# SOUTH SAN LUIS OBISPO COUNTY SANITATION DISTRICT

Post Office Box 339 Oceano, California 93475-0339  
1600 Aloha Oceano, California 93445-9735  
Telephone (805) 489-6666 FAX (805) 489-2765  
www.sslocsd.org

---

## Staff Report

**To:** Board of Directors  
**From:** Jeremy Ghent, District Administrator; Mychal Jones, Plant Superintendent  
**Date:** June 3rd, 2026  
**Subject:** **DISTRICT ADMINISTRATOR AND PLANT OPERATIONS REPORT**

This report represents ongoing information on the latest District staff activities on major capital projects and studies, programmatic initiatives, regional collaboration, miscellaneous activities, and Plant Operations. *Updates since the last report are provided in italics below:*

### **Capital Projects:**

#### **Cogeneration Project:**

- *Contract Language and Legal Review*

#### **Misc:**

- *District Administrator and Plant Superintendent met with the Public Works Director and Wastewater Chief Plant Operator for the City of Pismo Beach. This meeting was mainly for introductions of new staff.*
- *Discussions continue to advance between the City of Arroyo Grande, the Canyon Crest Neighborhood, and SSLOCSD regarding providing treatment for 54 homes.*

#### **Plant Tours:**

*None*

#### **Upcoming Meetings:**

*July 1<sup>st</sup> Final Budget*  
*July 1<sup>st</sup> Hearing to Consider Entering into an Energy Services Agreement*  
*August 5<sup>th</sup> Update on Canyon Crest Service Request*

## Plant Operations Report

There were no violations of the District's National Pollutant Discharge Elimination System (NPDES) Permit during the April to May 2026 reporting period. All regulatory required analyses were within Permit limitations.

### April 2026 Plant Data

April 2026	INF Flow MGD	INF Peak Flow MGD	INF BOD mg/L	EFF BOD mg/L	BOD % Removal	INF TSS mg/L	EFF TSS mg/L	TSS % Removal	Fecal Coliform MPN/100 mL	Chlorine Usage lbs/day
Low	2.14	3.1	294	4.7		325	8.0		<1	91
High	2.55	4.6	423	17.1		490	20.8		3	363
April 2026 AVG	2.29	3.51	354	11.2	96.8	371	14.2	96.2	1.0	210
April 2025 AVG	2.24	3.53	359	15.3	95.7	395	9.1	97.7	2.25	211
Limit	5.0			40/60/90	>80		40/60/90	>80	2000	

### May 2026 Plant Data

May 2026	INF Flow MGD	INF Peak Flow MGD	INF BOD mg/L	EFF BOD mg/L	BOD % Removal	INF TSS mg/L	EFF TSS mg/L	TSS % Removal	Fecal Coliform MPN/100 mL	Chlorine Usage lbs/day
Low	2.15	3.0	292	8.0		248	9.0		<1	121
High	2.47	3.9	352	16.0		431	19.0		2	182
May 2026 AVG	2.26	3.4	329	11.6	96.5	354	11.9	96.6	1.0	149
May 2025 AVG	2.22	3.4	445	7.7	98.3	385	3.4	99.1	2.34	120
Limit	5.0			40/60/90	>80		40/60/90	>80	2000	

### Operation and Maintenance Tasks

- Performed polymer trials on centrifuge and rotary drum thickening unit
- Rinsed and cleaned centrifuge building
- Cleaned and rebuilt centrifuge polymer skid
- Performed annual regulatory sampling of influent, effluent, biosolids, and chronic toxicity
- Thoroughly cleaned plant grounds
- Hach performed biannual field service on total suspended solids probes, ORP/pH probes, and controllers
- Troubleshoot reclaim water filter fault and replaced pressure sensor
- State Water Board performed a routine inspection of the District's facility. No violations were observed or reported.
- V. Lopez & Sons lowered District manhole on Pier Avenue as part of the County of San Luis Obispo's asphalt overlay project
- Checked and marked Underground Service Alerts
- Completed installation of new seal around Rotary Drum Thickener electrical control panel
- Collected waste and excess metal in preparation for recycling

- Performed weed abatement throughout facility
- Troubleshoot disinfection injection lines and cleared air lock
- Fabricated new scrap metal box
- Troubleshoot and replaced rotary lobe pump boots
- Installed new chemical pumping skid drain lines
- City of Pismo beach assisted Operations staff with uncovering a water leak
- Shutdown utility water to the facility and repaired water leak
- Troubleshoot thickened waste activated sludge pump No. 2 faults. District's electrical contractor, AutoSys LLC, identified main power conductors from variable frequency drive to the pump motor had failed. Locked out and tagged out control power and notified Redundancy Project construction contractor of defective power conductors.
- Began reorganizing and thoroughly cleaning Fixed Film Reactor storage area
- Performed confined space entry into Secondary Clarifier No. 2 to thoroughly clean launder, v-notch weir, and baffle.
- ACE Certified Tree Care cleared vegetation on District's sewer bridge, cut down trees in front of treatment plant, and cleared vegetation along back entry to treatment plant
- Landscaped plant grounds
- V. Lopez & Sons raised District manhole to grade on Pier Avenue as part of the County of San Luis Obispo's asphalt overlay project
- Ferguson Electric repaired and installed new light fixtures throughout facility
- Troubleshoot well sprinkler pumping system
- R.A. Batchelor Co. performed annual safety inspections of trunk crane and confined space retrieval systems
- Taft Electric performed the removal of thickened waste activated sludge pump No. 2 failed conductor.
- CMC Crew began Fireline cutback around treatment facility fenceline

### **Work Orders Completed**

- Test ran emergency standby generators and bypass pump
- Inspected digester vacuum/pressure relief valves
- Performed algae control on all clarifiers
- De-ragged primary sludge pump
- Performed preventative maintenance on aeration blowers
- Performed preventative maintenance on "Mr. Jackman"
- Performed preventative maintenance and oil sample on Fixed Film Reactor
- Calibrated ORP disinfection control probes
- Replaced boiler air intake filter
- Performed preventative maintenance on clarifier drives
- Cleaned variable frequency drive air filters

### **Training**

- Staff participated in annual fire extinguisher safety training

### **Call Outs**

- May 1<sup>st</sup> at 2:45am – RDT 1 Fault. Operations staff responded and inspected operations. Reset RDT fault and placed system back in operation.

**Staff**

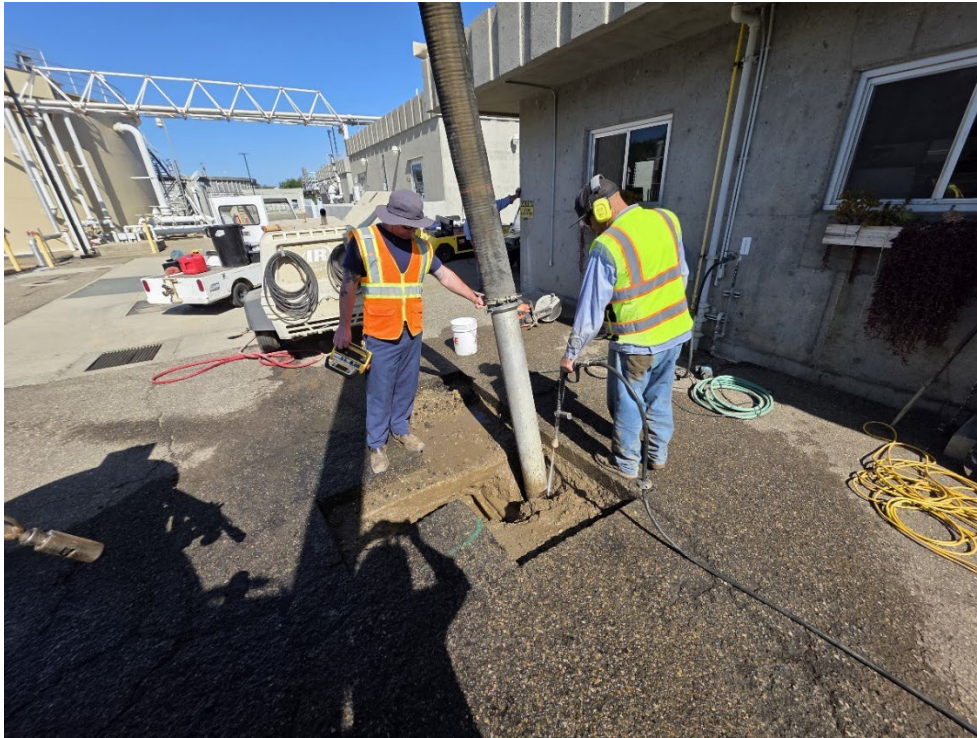

**City of Pismo Beach Staff and Operator Justin Musick use a vacuum truck to uncover a water leak.**



**Operations Supervisor, Mike Arias, and Operator Everardo perform an inspection of the waste activated sludge pump.**



**Construction contractor V. Lopez Jr. & Sons lowering a District manhole below grade as part of the County of San Luis Obispo's Pier Avenue Overlay Project.**